

# CAD/CAM System

# CONTACT

## Contact:

T: +386 (0)3 425 62 00

E: info@interdent.cc

## Export:

T: +386 (0)3 425 62 20

E: m.krajnovic@interdent.cc

## CAD/CAM Center:

T: +386 (0)3 425 62 43

E: cadcam@interdent.cc

## Servis:

T: +386 (0)3 425 62 06

E: servis@interdent.cc

## Education center:

T: +386 (0)3 425 62 14

E: i.brezovsek@interdent.cc



The headquarters of Interdent, Celje, Slovenia



Production facilities Interdent, Gornji Grad, Slovenia



## Interdent Slovenia

T: +386 (0)3 425 62 00

E: info@interdent.cc

## Interdent Croatia

T: +385 (0)1 387 36 44

E: interdent@interdent.hr

## Interdent Serbia

T: +381 (0)11 217 53 74

E: interdent@interdent.rs

## Interdent Czech

T: +420 274 783 114

E: interdent@interdent.cz

## Interdent Slovakia

T: +421 903 418 001

E: interdent@interdent.sk

# TABLE OF CONTENTS

---

CONTACT .....	2
INTERDENT CAD/CAM System.....	4
CC LITE.....	5
CC Force/Force Pro.....	6
CC Force+/Force+ Pro.....	7
Technical Comparison.....	8
Available options.....	9
CC newTRENDY+.....	10
CC TRENDY .....	11
CC newCOSMO.....	12
CC UNIVERSE .....	13
CC COOL .....	14
CC newCHIC .....	15
CC TRIM .....	16
END MILL TOOLS .....	17
FOR CC LITE, CC TRENDY, CC newTRENDY+,CC new COSMO, CC UNIVERSE, CC COOL, CC newCHIC.....	17
HOLDER FOR PREMIL ABUTMENTS .....	18
SCANSPRAY.....	18
ISOPRINT .....	18
LaAlloy .....	19
CC DISK NF CoCr.....	20
CC DISK EASY CoCr.....	20
CC DISK Ti5.....	21
CC DISK Zr HT Multilayer .....	22
CC DISK Zr SMILE Multilayer.....	22
CC DISK Zr / CC DISK Zr HT .....	23
CC DISK PEEK.....	24
CC DISK WAX .....	24
CC DISK PMMA .....	25
CC DISK PMMA Pink .....	26
CC DISK PMMA Transparent.....	26
CC DISK PMMA X-Ray Opaque.....	26
SUPPORT AND EDUCATION.....	27
MILLING CENTER.....	28

# INTERDENT CAD/CAM System

With more than 45 years of experience in dentistry where the vision of the company and all employees is to produce quality products and where end user has a decisive importance, company Interdent offers you a complete solution in the CAD/CAM field.



Many years of research, users opinions and preferences as well as mutual cooperation contributed and created efficient milling units CC LITE, CC newCOSMO, CC TRENDY, CC newTRENDY+, CC COOL, CC newCHIC, CC UNIVERSE, CC Force, CC Force Pro, CC Force+, CC Force+ Pro and a trim unit CC TRIM, accurate scanners and excellent materials. Complete offer presents an open system, designed for anyone who wants to introduce advanced technology in their laboratory, which will provide flexibility, accuracy and independence.



With Interdent, easy-to-use advanced technology and excellent material are supported by an expert support that is available to you throughout the entire process, from your wishes and ideas for the purchase to education and quick resolution of any problems occurring in their use.



# CC LITE

5-axis milling unit for dry milling with simple operation without the use of compressed air. It is suitable for discs or blocks of almost all materials from composites to zirconia.

CC LITE milling unit is suitable for dental laboratories and practice labs due to its innovative and simple operation.

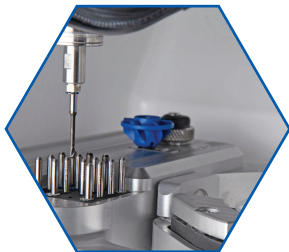

**Main motor:**  
High-frequency spindle with electromechanical tool chang

**Motor speed:**  
60.000 rpm

**Engine power:**  
800 W

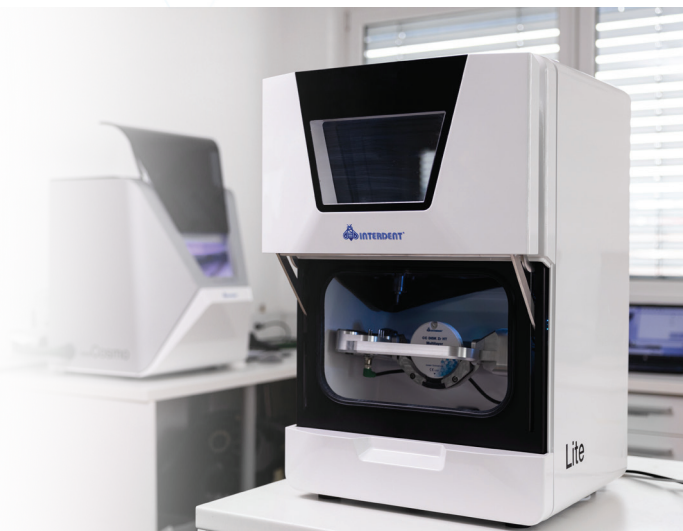

The CC LITE has a holder for up to 17 tools - 16 standard tools and an AIRTOOL of diameter Ø 3mm and maximum length 40mm. It is possible to mill discs of thickness 10 – 40 mm and blocks with a use of additional holder. Operation without the use of compressed air with the innovative AIRTOOL. Simple operation with the integrated Interdent dental CAM software featuring DIRECTMILL technology – no payable licence fees.

#### Advantages:

- Mills almost all materials in a 98.5 mm disc format,
- holders available for 110 mm discs and blocks.
- Integrated CAM software for immediate workflow (unpack, connect and start milling!) with maximum freedom in the choice of materials and scanners.
- 3 µm repetition accuracy.
- Easy service and ease of use.
- Cast aluminium body for low vibration in operation.
- No compressed air needed due to innovation of the CC LITE - AIRTOOL. The AIRTOOL (patent pending) uses its turbine blades to generate an air flow with no compressor or compressed air connection, which reliably keeps the workpiece free of dust and chippings. They are removed by vacuum from a dust collector.
- Automatic tool changer for 1 disc and for up to 6 blocks of different sizes.
- Benefits of optimum efficiency – maximum freedom of milling with minimal operating costs.
- Greatest indication diversity with a rotating angle of ± 35° in the 5th axis and discs up to 40 mm thick.
- Lightweight machine and service-optimized design for easy transport, flexibility of use and environmentally friendly shipping.
- Novelty: C-holder for 90° machining of anterior teeth.
- Fast machining times and the best production results.

#### ORDER NR.

564	CC Lite
641	CC Lite Drills set, á 13
CCZ200-R3D-40-T	2 mm round airtool 40 mm
CCP250-F1-40-T	2,5 mm straight airtool 40 mm
CCC200-R1D-40-T	2 mm round diamond coated 40 mm

#### Technical data

Number of axes	5	Capacity of end mill tools	16 + 1 AIRTOOL – automatic changeover
Working area, A axis	360°	Milling options	Dry milling
Working area, B axis	± 35°	Interface	InterdentCAM
Linear axes X, Y, Z axis	Precision ball screws, r.a. ± 0,003 mm	Power supply	100-240 V / 50-60 Hz
Construction	Massive aluminum cast	Dimensions W x H x D	472 x 734 x 484 mm
Motor speed	Up to 60,000 rpm	Weight	47 kg
Motor power	800 W (Pmax)		

#### Material

Composites, PMMA, Wax, Zirconia, CoCr sintered metal, PEEK

# CC Force/Force Pro

5-axis milling units are designed for wet and dry milling of discs and blocks. Equipped with a powerful 2.2 kW spindle, they offer a versatile solution for processing all kinds of materials. The CC Force Pro additionally features an automatic disc changer for enhanced efficiency and continuous operation.

The CC Force and CC Force Pro is an excellent choice for users who work with soft materials, while still requiring the flexibility to process metals (titanium and CoCr) and other materials that require wet milling, such as glass ceramics and lithium disilicate. The “zero clamping” pneumatic disc release system allows seamless job interruption—pause a process, change supports or materials, and resume operations without compromising accuracy.

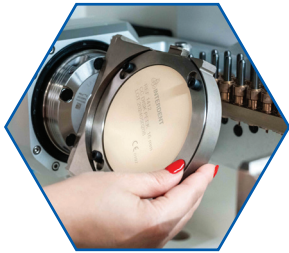

**Motor speed:**  
60.000 rpm  
**Engine power:**  
2.2 kW



Equipped with a 2.2 kW spindle, it delivers precise and reliable performance for a wide range of metal applications, including abutments and bars.

For extended production, the CC Force Pro is equipped with a four-position disk changer, enabling up to 48 hours of continuous, unattended milling.

#### Advantages:

- Stainless steel monocoque frame for maximum rigidity.
- Optimal chip extraction. The suction nozzle is integrated with the spindle, ensuring chip extraction occurs as close to the tool as possible.
- A/B axis movements.
- Optimal cooling and tool lubrication. Air and liquid nozzles are also spindle-integrated, providing consistent cooling and lubrication throughout the machining process.
- Starter KIT tools for advanced machining.
- A smart interface for fast workflows.

#### ORDER NR.

540	CC Force
541	CC Force Pro

#### Technical data

<b>Number of axes</b>	5	<b>Capacity of end mill tools</b>	Automatic with 22 positions
<b>Working area, A, B axis</b>	360°	<b>Milling options</b>	Wet or Dry
<b>Working area, B axis</b>	± 40°	<b>Interface</b>	DF Panel
<b>Construction</b>	Stainless steel monocoque chamber frame	<b>Touch screen tablet</b>	Integrated
<b>Motor speed</b>	60.000 rpm	<b>Power supply</b>	230 V
<b>Motor power</b>	2.2 kW	<b>Dimensions W x H x D</b>	Force 650 x 830 x 720 mm Force Pro 845 x 835 x 720 mm
<b>Air pressure</b>	7 bar 100 l/min	<b>Weight</b>	Force 180 kg Force Pro 190 kg

**Material** Zirconia, PEEK, PMMA, Composite, Titanium, CoCr, glass ceramic, hybrid ceramic, lithium disilicate, titanium premilled abutments

# CC Force+/Force+ Pro

5-axis milling units are designed for wet and dry milling of discs and blocks. Equipped with a powerful 3.0 kW spindle, they offer a versatile solution for processing all kinds of materials. The CC Force+ Pro additionally features an automatic disc changer for enhanced efficiency and continuous operation.

The CC Force+ delivers high machining speeds for continuous metal processing, while its robust design makes it well-suited for the demanding production volumes of modern laboratories. The “zero clamping” pneumatic disc release system allows seamless job interruption—pause a process, change supports or materials, and resume operations without compromising accuracy.



**Motor speed:**  
60.000 rpm  
**Engine power:**  
3.0 kW  
**Brushless motor**



The CC Force+ Pro sets new standards in quality and machining speed within the compact milling machine segment. Its ultra-rigid structure and high-end mechanical components ensure outstanding performance and reliability.

The “zero clamping” pneumatic disc release system allows seamless job interruption—pause a process, change supports or materials, and resume operations without compromising accuracy.

For extended production, the CC Force Pro+ is equipped with a four-position disk changer, enabling up to 48 hours of continuous, unattended milling. It also supports absolute optical scales with accuracy of up to 0.1 µm.

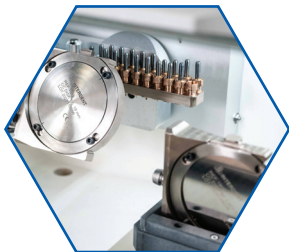

Automatic disk changer



Optimal chip extraction and tool lubrication



C-CLAMP Support

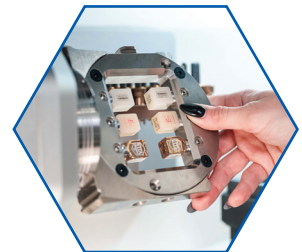

6-position blocks holder

## ORDER NR.

542	CC Force+
543	CC Force+Pro

## Technical data

Number of axes	5	Capacity of end mill tools	Automatic with 22 positions
Working area, A axis	360°	Milling options	Wet or Dry
Working area, B axis	± 40°	Interface	DF Panel
Construction	Stainless steel monocoque chamber frame	Touch screen tablet	Integrated
Motor speed	60.000 rpm	Power supply	230 V
Motor power	3 kW	Dimensions W x H x D	Force+ 650 x 835 x 720 mm Force+ Pro 845 x 835 x 720 mm
Air pressure	6 bar - 25 l/min	Weight	Force+ 180 kg Force+ Pro 200 kg

**Material** Titanium, CoC, Zirconia, PEEK, PMMA, Composite, glass ceramic, hybrid ceramic, lithium disilicate, titanium premilled abutments.

# Technical Comparison

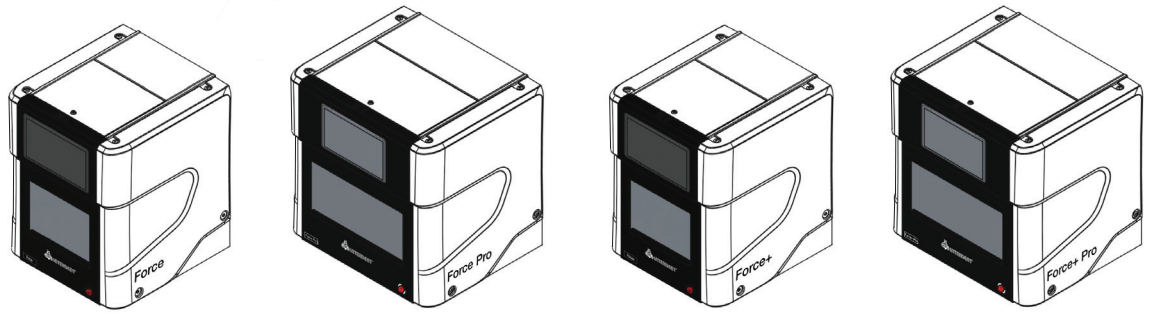

	CC Force	CC Force Pro	CC Force+	CC Force+ Pro
<b>POSITIONING</b>				
<b>Best for</b>	Soft materials + occasional titanium	Soft materials + titanium	High-volume metal milling	Maximum precision metal production
<b>SPINDLE &amp; MOTORS</b>				
<b>Spindle</b>	2.2 kW	2.2 kW	3.0 kW	3.0 kW
<b>Motor speed</b>	60,000 rpm	60,000 rpm	60,000 rpm	60,000 rpm
<b>Motors</b>	Stepper with encoders	Stepper with encoders	Brushless, 23-bit abs. encoders	Brushless, 23-bit abs. encoders
<b>AXES &amp; TOOLING</b>				
<b>Milling axes</b>	5-axis continuous	5-axis continuous	5-axis continuous	5-axis continuous
<b>Tool shank</b>	6 mm	6 mm	6 mm	6 mm
<b>Tool changer</b>	Auto, 22 positions	Auto, 22 positions	Auto, 22 positions	Auto, 22 positions
<b>Rotation A / B</b>	360° / ± 40°	360° / ± 40°	360° / ± 40°	360° / ± 40°
<b>AUTOMATION &amp; FLEXIBILITY</b>				
<b>Pod release</b>	Pneumatic - optional	Pneumatic - included	Pneumatic - optional	Pneumatic - included
<b>4-pos disk loader (48h)</b>	Not available	Included	Not available	Included
<b>Optical scales (0.1 um)</b>	Not available	Not available	Not available	Optional
<b>Self-calibration</b>	Optional	Optional	Optional	Optional
<b>MATERIALS</b>				
<b>Supported</b>	Titanium, CoC, Zirconia, PEEK, PMMA, Composite, glass ceramic, hybrid ceramic, lithium disilicate, titanium premilled abutments.			
<b>POWER &amp; PHYSICAL</b>				
<b>Air supply</b>	7 bar / 100 l/min	7 bar / 100 l/min	6 bar / 100 l/min	6 bar / 100 l/min
<b>Dimensions (L x D x H)</b>	650 x 720 x 830 mm	845 x 720 x 835 mm	650 x 720 x 830 mm	845 x 720 x 835 mm
<b>Weight</b>	180 kg	190 kg	180 kg	200 kg

# Available options

Even if they perform similar jobs, the various laboratories may have different needs depending on their work cycle, the materials they mill, and their customers. To meet these needs, we provide a series of accessories that allow you to customize the individual machine, both at the time of the order and, in many cases, even after installation at the customer's site.

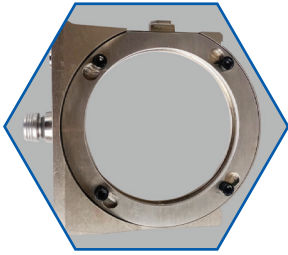

**Standard holder**  
Closed, high-rigidity support for precision machining. The holder is suitable for mounting in the disk changer.  
REF 526

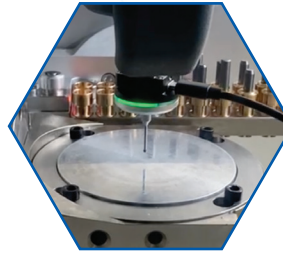

**Self-calibration**  
To maintain high precision, each milling machine must be cyclically calibrated to its internal handling parts.  
REF 532

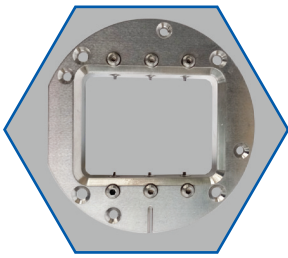

**6-position blocks support**  
The special multifunctional support for premilles and disilicates allows the insertion of custom bushings, adaptable to any type of connection.  
REF 530

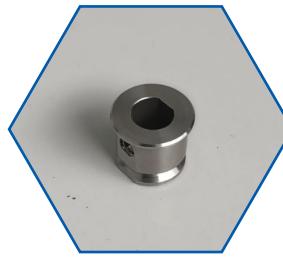

**Adapter for premill (Nt trading-Dess)**  
REF 524

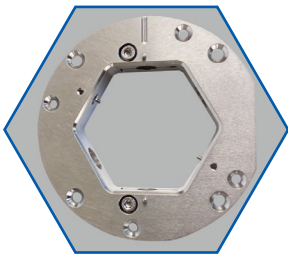

**Multiple support**  
It allows you to machine two blocks, two premilled and, thanks to the interchangeable bushings, two custom supports.  
REF 528

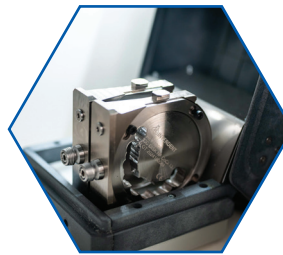

**Automatic disk charger**  
The 4-disk loader, which can be installed, allows you to automate the work cycle on four different pod supports, which can mount pods of different materials, thicknesses, or even premilled and disilicates.  
REF 527



**C-CLAMP Support**  
The open support enables the processing of soft materials, allowing extensive access to the buccal region.  
REF 523



**Dedicated cabinet**  
All milling units can be equipped with a dedicated support table that accommodates the filtering and lubrication system, the cooling system and the aspirator in a practical and functional way.  
REF 520 - CC Force in CC Force+  
REF 521 - CC Force Pro and CC Force+ Pro

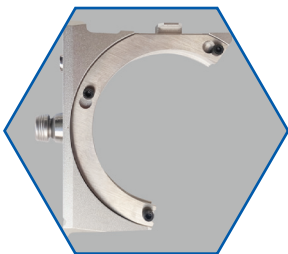

**Palletizable C-Clamp**  
Allows the processing of the buccal area, the support is suitable to be mounted in the storage loader.  
REF 529

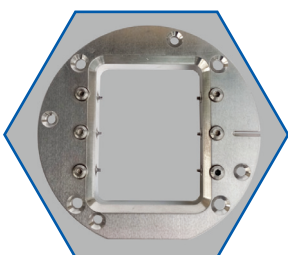

**Premilled 6-position support**  
REF 530

## ORDER NR.

517	Starter set for wet milling 15 instr. (Metal/PMMA/Comp)
518	Starter set for universal milling (metal/PMMA/comp/Zr) - 16 instr.
519	Starter set for blocks - wet - 3 instr.

# CC newTRENDY+

5-axes milling unit for dry milling with an all-new look, and 60 % more powerful spindle!

That means you can always go all out when milling, making it much easier to machine tough materials like cobalt-chrome. Thanks to its proven reliability, the CC newTrendy+ is a true driver of performance in any laboratory.



**Main motor:**  
High-frequency spindle,  
synchronous with pneumatic tool clamping  
**Motor speed:**  
60.000 rpm  
**Engine power:**  
820 W



CC newTrendy+ has a holder for up to 16 tools of diameter  $\varnothing$  3 mm with maximum length 40 mm. It can process discs up to a thickness of 40 mm.

Keeping it all together - Tools and material blanks are stored in the machine's practical accessory drawer, so they are always close at hand. An administrated tool board for milling tools is also integrated into the drawer. Its numbered slots are managed using the DENTALCAM software, creating an active tool pool of a total of 30 tools.

#### Advantages:

- Powerful 820 W, 60.000 rpm spindle.
- Mills the toughest materials on the market, incl. CoCr.
- Automatic changer for 16 tools.
- 3  $\mu$ m repetition accuracy.
- DIRECTDISC Technology for tool-free disc fixation – insert your workpieces in seconds.
- Webcam in the working chamber for remote monitoring and service.
- Integrated Ioniser and improved air circulation for easy machine cleaning.
- Less vibration for first-class surface quality.
- Practical accessory drawer with Administrated Tool Board for milling tools.

#### ORDER NR.

557	CC newTRENDY+
591-22	Drills set CC newTRENDY+, á 22

#### Technical data

Number of axes	5	Capacity of end mill tools	16 – automatic changing
Working area, A, B axis	360°	Milling options	Dry
Working area, B axis	$\pm$ 35°	Interface	InterdentCAM
Construction	Massive aluminum cast	Power supply	100-240 V / 50-60 Hz
Motor speed	60.000 rpm	Dimensions W x H x D	455 x 630 x 550 mm
Motor power	820 W	Weight	91 kg
Air pressure	6 bar: 50 l/min to 8 bar: 64 l/min (without ionisation) · 6 bar: 80 l/min to 8 bar: 102 l/min (with ionisation) · air purity according to ISO 8573 1:2010	Linear axes X, Y, Z axis	Precision ball screws · motors with resolution < 1 $\mu$ m · ground precision guides made of high-alloyed steel · repetition accuracy $\pm$ 0.003 mm

#### Material

PEEK, PMMA, wax, zirconia, composites, CoCr

# CC TRENDY

5-axis milling unit for dry milling!

Due to its size CC TRENDY milling unit is suitable for smaller and middle size laboratories producing materials which are milled dry.



**Main motor:**  
SFK 300P  
**Motor speed:**  
60.000 rpm  
**Engine power:**  
500 W

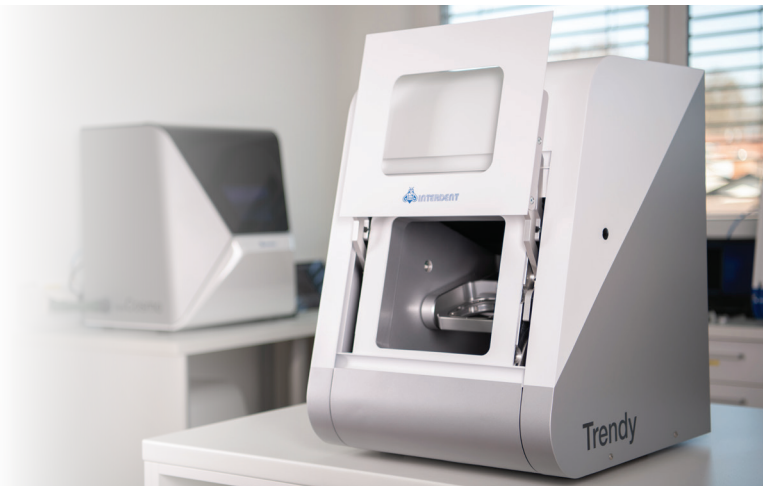
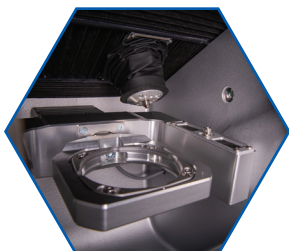

The CC TRENDY has a holder for up to 16 tools of diameter  $\varnothing$  3 mm with maximum length 40 mm.

### The CC Trendy is designed for precision and longevity.

- Powerful and highly precise synchronous spindle.
- Sophisticated protective mechanisms - A special design creates an internal vacuum in the milling chamber, drawing damaging debris and powders away from the spindle, contributing to extended spindle life.
- Practical drawer for accessories.
- The b-axis will rotate up to 35 degrees, the higher rotation range allows for the milling of discs up to 40mm thick.
- Extremely stable during milling.

### ORDER NR.

561	CC TRENDY
591-22	Drills set CC TRENDY, á 22

### Technical data

Number of axes	5	Capacity of end mill tools	16 – automatic changing
Working area, A axis	360°	Milling options	Dry
Working area, B axis	± 35°	Interface	InterdentCAM
Construction	Massive aluminum cast	Power supply	100-240 V / 50-60 Hz
Motor speed	60.000 rpm	Dimensions W x H x D	450 x 630 x 530 mm
Motor power	500 W	Weight	91 kg
Air pressure	6 bar 40 l/min / 8 bar 50 l/min	Linear axes X, Y, Z axis	165,5 x 108 x 93 mm

### Material

Composite, zirconium, wax, CoCr, PEEK, PMMA

# CC newCOSMO

Compact 5-axis milling unit for dry and wet milling with disc changer.

Due to its size and the wet or dry milling options, the CC newCOSMO milling unit is suitable for laboratories producing restorations from a wide range of different materials.

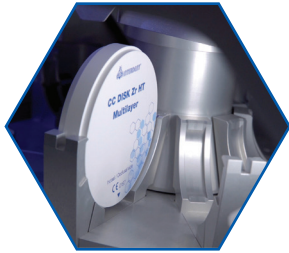

**Main motor:**  
SFZ400P  
**Motor speed:**  
80.000 rpm  
**Engine power:**  
800 W



The CC newCOSMO has a holder for up to 16 tools of diameter  $\varnothing$  3 mm with maximum length 40 mm. It can mill smaller blocks and discs with  $\varnothing$  98 mm.

#### Advantages:

- Coloured working chamber illumination indicates milling status.
- Webcam for remote monitoring.
- Automatic cleaning and drying - "DirectClean Technology".
- Integrated ionizers.
- Tool-free material mount (1-click mounting).
- Revolutionary material loading with "DirectDiscTechnology" for 10 discs.
- Holder for 6 blocks. It can mill discs  $\varnothing$  98mm, max thickness 40mm or blocks max size 20 x 20 x 40 mm (W/H/L).
- End mill tools and grinds the toughest materials on the market including Ti and CoCr.
- Automatic changer of tools.
- Automatic verification of the mill length.
- Integrated container with cooling liquid.
- Network connection capability.
- One of the fastest machines on the market.

#### ORDER NR.

556	CC newCOSMO
594N	Drills set CC newCOSMO, á 28

#### Technical data

Number of axes	5	Capacity of end mill tools	16 - automatic changer
Working area, A axis	360°	Milling options	Wet or dry - integrated water container
Working area, B axis	$\pm 35^\circ$	Interface	InterdentCAM
Construction	Massive aluminum cast	Power supply	100-240 V / 50-60 Hz
Motor speed	80.000 rpm	Dimensions W x H x D	580 x 700 x 600 mm
Motor power	800 W	Weight	150 kg
Air pressure	6-8 bar 120 l/min		

#### Material

Composite, zirconium, wax, CoCr, Peek, PMMA, glass ceramic, hybrid ceramic, lithium disilicate, titanium, titanium premilled abutments

# CC UNIVERSE

Compact and precise 5-axis milling unit for dry and wet milling (optional module).

Highly versatile milling unit with five simultaneously operating axes and a blank changer for eight blanks. Designed for both dry and wet milling (optional).

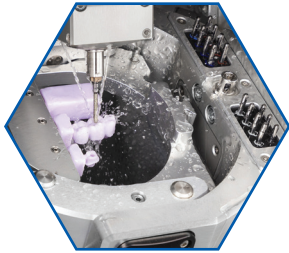

**Main motor:**  
SFS 300P  
**Motor speed:**  
60.000 rpm  
**Engine power:**  
600 W



The CC UNIVERSE has a holder for up to 16 tools of diameter  $\varnothing$  3 mm with maximum length 40 mm.

#### Advantages:

- Milling around the clock due to automatic changer for 8 discs, 24 blocks or 48 prefabricated abutments.
- Processes all types of materials, including CoCr, titanium and glass-ceramics.
- Automatic changer for 16 tools.
- 3 ionizers for a clean working chamber.
- Optional wet-grinding module converts the CC UNIVERSE into a wet-processing machine.

#### ORDER NR.

589	CC UNIVERSE
587-22	Drills set CC UNIVERSE, á 22
588N	Drills set CC UNIVERSE, á 9
581	Block holder for CC UNIVERSE
583	Power supply wet grinding option RCD CC UNIVERSE

#### Technical data

Number of axes	5	Capacity of end mill tools	16 - automatic changer
Working area, A axis	360°	Milling options	Wet (with wet-grinding module) or Dry
Working area, B axis	± 30°	Interface	InterdentCAM
Construction	Massive aluminum cast	Power supply	100-240 V / 50-60 Hz
Motor speed	60.000 rpm	Dimensions W x H x D	700 x 561 x 444 mm
Motor power	600 W	Weight	106 kg
Air pressure	6 bar 60l/min, 8 bar 73l/min		3 integrated ionizers
Material	Composite, zirconium, wax, CoCr, Peek, PMMA, glass ceramic, hybrid ceramic, lithium disilicate, titanium premill abutments		

# CC COOL

4-axis milling unit for wet and dry milling of blocks for chairside production and with CAM Software included.

CC COOL milling unit is the best economical solution for dental practices due to the compact design, light weight and no use of compressed air. It processes materials from PMMA to glass ceramics.



**Main motor:**  
High-frequency spindle with electromechanical tool change  
**Motor speed:**  
60.000 rpm  
**Engine power:**  
800 W



The CC Cool has a holder for up to 6 tools and an AIRTOOL. Operation without the use of compressed air with the innovative AIRTOOL.

#### Advantages:

- Mills almost all materials up to 45 mm in length including glass ceramics, composites, zirconium oxide and PMMA in block format.
- Easy entry into in-house production.
- Integrated CAM software for immediate workflow (unpack, switch on and start milling) with maximum freedom in the choice of materials and suitable for all CAD software.
- Quick and easy switch between wet grinding and optional dry milling. Multi-compartment for cooling liquid tank or optional dry milling container.
- Quick restorations in just one session.
- The PUREWATER Technology ensures that the closed liquid circuit in the machine requires no grinding additives. Meaning easy disposal and even lower running costs.
- The optional dry container enables you to mill materials such as zirconia, PMMA and various composites with no cooling water or compressed air.
- No compressed air needed due to innovation of the CC Cool - AIRTOOL. The AIRTOOL (patent pending) uses its turbine blades to generate an air flow with no compressor or compressed air connection, which reliably keeps the workpiece free of dust and chippings. They are removed by vacuum from a dust collector.
- 3 µm repetition accuracy.
- Machine design optimized for minimal weight and modular design for easy transport, flexibility of use and environmentally friendly shipping.

#### ORDER NR.

565	CC COOL
566	Drills set CC COOL, á 5
567	Drills set CC COOL, á 13 + ATB tank

#### Technical data

Number of axes	4	Capacity of end mill tools	6 + 1 AIRTOOL – automatic changeover
Working area, A axis	+190° to -10°	Milling options	Wet/dry milling
Linear axes X, Y, Z axis	Precision ball screws, r.a. ± 0,003 mm	Interface	InterdentCAM
Construction	Sturdy aluminium welded structure	Power supply	100-240 V – 50/60 Hz, 500 W
Motor speed	Up to 60.000 rpm	Dimensions W x H x D	360 × 490 × 370 mm
Motor power	800 W	Weight	28 kg
Material	Glass ceramic, hybrid ceramic, lithium disilicate, wax, composite, zirconium, PMMA, Peek		

# CC newCHIC

4-axis milling unit for wet milling of blocks, specially designed for dental clinics and laboratories as well.

Due to its size and the wet milling option, the CC newCHIC milling unit is suitable for dental clinics and dental laboratories which only want to mill small blocks, or use it as a second milling unit.



**Main motor:**  
SFZ 170P  
**Motor speed:**  
100.000 rpm  
**Engine power:**  
340 W



The CC newCHIC has a holder for up to 6 tools of diameter Ø 3 mm with maximum length 35 mm.

#### Advantages:

- Smart touchscreen operation.
- Coloured working chamber illumination indicates milling status.
- Webcam for remote monitoring.
- Automatic changer for 6 tools.
- Colour coded tools.
- Automatic changer of tools with the help of compressed air.
- Automatic verification of the mill length.
- Tool-free material mount (1-click mounting).
- Working chamber with anti-graffiti coating for minimum cleaning effort.
- Removable and dishwasher-proof water tank.
- Integrated Wi-Fi module.
- Extremely quiet, due to internal insulation and thickwalled die casting housing.
- No external compressed air supply necessary.
- Direct integration with CAD SW.

#### ORDER NR.

594	CC newCHIC
593N	Drills set CC newCHIC, á 26

#### Technical data

<b>Number of axes</b>	4	<b>Capacity of end mill tools</b>	6
<b>Working area, A axis</b>	200°	<b>Milling options</b>	Wet – integrated water container
<b>Linear axes X, Y, Z axis</b>	Precision ball screws, r.a. ± 0,003 mm	<b>Interface</b>	InterdentCAM
<b>Construction</b>	Massive aluminum cast	<b>Power supply</b>	100-240 V / 50-60 Hz
<b>Motor speed</b>	100.000 rpm	<b>Dimensions W x H x D</b>	471 x 507 x 572 mm
<b>Motor power</b>	340 W	<b>Weight</b>	66 kg
<b>Air pressure</b>	Integrated compressed air production		
<b>Material</b>	Glass ceramic, hybrid ceramic, lithium disilicate, composite, zirconium, PMMA, titanium premilled abutments		

# CC TRIM

The new CC Trim enables you to automate the precision trimming of occlusal appliances. You can expect the very best results in the shortest time with no arduous reworking. The machined fabrication also ensures a consistently high quality.



Meant for:

- aligners,
- bite splints,
- grinding splints,
- sports mouthguards.



Meticulous attention has been paid to the details: for example, no separate extraction system is required – thanks to the practical collection tray for chips.

With a machine weight of only 25 kg and no use of compressed air, the compact CC Trim offers maximum flexibility in terms of the installation site. The CC Trim impresses with its precise results and outstanding reliability.

Saves time and work! Benefit from the machining of aligners in under 60 seconds. This saves you a lot of time compared to manual production – and on top of that you gain the high precision of CNC production. The tool-free clamping system further simplifies your work processes. This quick workpiece change enables you to produce entire series of aligners quickly and easily.

Content of drills set:

2 x P140-R1-60 - single tooth radius cutters - for aligners and plastics

1 x P300-R2-60 - tooth radius cutter double - for aligners and plastics

2 x P200-R1-6 - single tooth radius cutters - for splints and plastics

Tool length is 60 mm.

#### ORDER NR.

559	CC TRIM
642	Drills set CC TRIM, á 5
CCP200-R1-60	End mill tools for foils of thickness 2-5 mm

#### Technical data

<b>Number of axes</b>	3+1	<b>Holder systems</b>	Holder for tool-free clipping in of the aligners
<b>Working area, B axis</b>	Rotation angle: 360°, infinite	<b>Fields of application</b>	Dry machining
<b>Linear axes X, Y, Z axis</b>	X-axis: rack and pinion drive · Y-/Z-axis: trapezoidal screw spindles · motor resolution 10 µm · max. axial backlash 0.06 mm	<b>Interface</b>	InterdentCAM
<b>Construction</b>	Sturdy aluminum structure	<b>Power supply</b>	100–240 V · 50/60 Hz, 320 W
<b>Motor speed</b>	Up to 60,000rpm	<b>Dimensions W x H x D</b>	360 × 490 × 370 mm
<b>Motor power</b>	800 watts	<b>Weight</b>	25 kg
<b>Air pressure</b>	Operation without compressed air	<b>Lighting</b>	RGB LED lighting with status indication

#### Material

Thermo-formed plastic foil - Aligners and other splints

# END MILL TOOLS

FOR CC LITE, CC TRENDY, CC newTRENDY+, CC new COSMO, CC UNIVERSE, CC COOL, CC newCHIC

## End mill tools UNIVERSAL

ORDER NR.:	SIZE	SHAPE	LENGTH
CCU060-R2-35	0,6 mm	round, 2 teeth	35 mm
CCU060-R2-40	0,6 mm	round, 2 teeth	40 mm
CCU120-F2-35	1,2 mm	straight, 2 teeth	35 mm
CCU120-F2-40	1,2 mm	straight, 2 teeth	40 mm
CCU030-R2-35	0,3 mm	round, 2 teeth	35 mm
CCU030-R2-40	0,3 mm	round, 2 teeth	40 mm
CCU050-F2-35	0,5 mm	straight, 2 teeth	35 mm
CCU050-F2-40	0,5 mm	straight, 2 teeth	40 mm

## End mill tools for ZIRCONIUM

ORDER NR.:	SIZE	SHAPE	LENGTH
CCZ100-R2-35	1,0 mm	round, 2 teeth	35 mm
CCZ100-R2-40	1,0 mm	round, 2 teeth	40 mm
CCZ200-R3-35	2,0 mm	round, 3 tooth	35 mm
CCZ200-R3-40	2,0 mm	round, 3 tooth	40 mm
CCZ060-R2D-40	0,6 mm	round, 2 teeth, diamond coated	40 mm
CCZ100-R2D-40	1,0 mm	round, 2 teeth, diamond coated	40 mm
CCZ200-R3D-40	2,0 mm	round, 3 teeth, diamond coated	40 mm
CCZ120-F2D-40	1,2 mm	straight, 2 teeth, diamond coated	40 mm
CCZ200-R3D-40-T	2,0 mm	round airtool, diamond coated	40 mm
CCZ060-R2D-35	0,6 mm	round, 2 teeth, diamond coated	35 mm
CCZ100-R2D-35	1,0 mm	round, 2 teeth, diamond coated	35 mm
CCZ200-R3D-35	2,0 mm	round, 3 teeth, diamond coated	35 mm
CCZ120-F2D-35	1,2 mm	round, 2 teeth, diamond coated	35 mm

## End mill tools for COMPOSITE

ORDER NR.:	SIZE	SHAPE	LENGTH
CCC100-R2-35	1,0 mm	round, 2 teeth	35 mm
CCC100-R2-40	1,0 mm	round, 2 teeth	40 mm
CCC200-R2-35	2,0 mm	round, 2 teeth	35 mm
CCC200-R2-40	2,0 mm	round, 2 teeth	40 mm
CCC200-R1D-40-T	2,0 mm	round diamond coated, artitool	40 mm
CCC100-R1D-35	1,0 mm	round, 1 tooth, diamond coated	35 mm
CCC200-R1D-35	2,0 mm	round, 2 teeth, diamond coated	35 mm
CCC100-R1D-40	1,0 mm	round, 1 tooth, diamond coated	40 mm
CCC200-R1D-40	2,0 mm	round, 1 tooth, diamond coated	40 mm
CCC200-R1D-40-T	2,0 mm	round, 1 tooth, diamond coated, airtool	40 mm

## End mill tools for CoCr and Ti

ORDER NR.:	SIZE	SHAPE	LENGTH
CCM060-R2-32	0,6 mm	round, 2 teeth	32 mm
CCM060-R2-35	0,6 mm	round, 2 teeth	35 mm
CCM100-R2-32	1,0 mm	round, 2 teeth	32 mm
CCM100-R2-35	1,0 mm	round, 2 teeth	35 mm
CCM200-R4-35	2,0 mm	round, 4 teeth	35 mm
CCM200-R4-32	2,0 mm	round, 4 teeth	32 mm
CCM200-R4-35	2,0 mm	round, 4 teeth	35 mm
CCM120-T2-32	1,2 mm	torus, 2 teeth	32 mm
CCM120-T2-35	1,2 mm	torus, 2 teeth	35 mm

## End mill tools for PMMA

ORDER NR.:	SIZE	SHAPE	LENGTH
CCP100-R2-35	1,0 mm	round, 2 teeth	35 mm
CCP100-R2-40	1,0 mm	round, 2 teeth	40mm
CCP200-R2-35	2,0 mm	round, 2 teeth	35 mm
CCP200-R2-40	2,0 mm	round, 2 teeth	40 mm
CCP250-F1-35	2,5 mm	straight, 1 tooth	35 mm
CCP250-F1-40	2,5 mm	straight, 1 tooth	40 mm
CCP250-F1-40-T	2,5 mm	straight airtool	40 mm
CCP100-R1-35	1,0 mm	round, 1 tooth	35 mm
CCP100-R1-40	1,0 mm	round, 1 tooth	40 mm
CCP200-R1-35	2,0 mm	round, 1 tooth	35 mm
CCP200-R1-40	2,0 mm	round, 1 tooth	40 mm
CCP140-R1-60	1,4 mm	round, 1 tooth	60 mm
CCP300-R2-60	3,0 mm	round, 2 teeth	60 mm

## End mill tools for GLASS CERAMIC

ORDER NR.:	SIZE	SHAPE	LENGTH
CCG060-R-35	0,6 mm	round	35 mm
CCG060-T-35	0,6 mm	torus	35 mm
CCG100-R-35	1,0 mm	round	35 mm
CCG120-T-35	1,2 mm	torus	35 mm
CCG240-R-35	2,4 mm	round	35 mm

CC LITE	Max mill length is 40 mm.
CC NewTRENDY+	Max mill length is 40 mm.
CC TRENDY	Max mill length is 40 mm.
CC NewCOSMO	Max mill length is 40 mm.
CC UNIVERSE	Max mill length is 40 mm.
CC COOL	Max mill length is 40 mm.
CC NewCHIC	Max mill length is 35 mm.

Size      2 teeth      Diamond coated

**Z100 - R2D - 40**      Mill length

- Z - Zirconium
- C - Composite
- U - Universal
- P - Pmma, wax
- M - CoCr, Ti
- G - Glass Ceramic
- R - Round
- F - Straight
- T - Torus

# HOLDER FOR PREMIL ABUTMENTS

Abutment holders are available for CC newCHIC, CC newCOSMO, CC newTRENDY+ and CC UNIVERSE. Abutment holders are different depending on the system.



ORDER NR.

- 596 Holder for CC newCOSMO
- 597 Holder for CC Trendy, CC newTRENDY+ and CC Universe

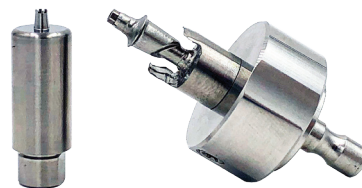

ORDER NR.

- 568 Holder for CC newCHIC

## SCANSPRAY

For extraoral use, on prepared models and impressions prior to scanner exposure. Shiny surfaces, such as alloys for example, might be difficult to scan. Use of scan spray which can be easily removed with water afterwards is highly recommended for such surfaces.



ORDER NR.

- 95 Scanspray, á 200 ml



## ISOPRINT

ISOPRINT is a water-based, alcohol-free isolator intended for the isolation of SLA/DLP 3D-printed models when applying cold polymerising acrylic materials. It provides good insulation and is easily removed with warm water.



ORDER NR.

- 150 Isoprint, á 100 g



# LaAlloy

Co-based non-precious dental alloy powder, intended for the production of fixed and removable dental restorations using SLM printing technology, type 5. Free of beryllium, nickel, cadmium and lead. Fulfils the recommendations of the EN ISO 22674 and EN ISO 9693 standards.

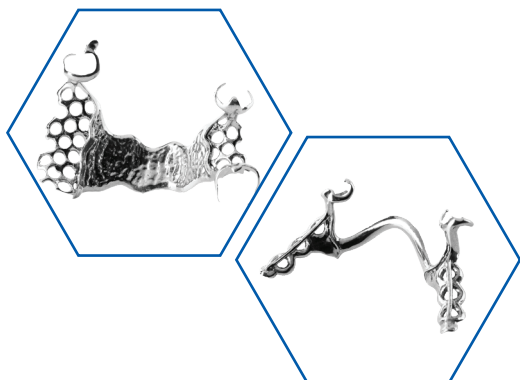

CE 0197  
MD

## Advantages:

- Due to its homogeneity and particle distribution, it provides excellent flow properties during the manufacturing process.
- CTE 14.4 allows great flexibility in the choice of metal ceramics and composites.
- Universal non-precious alloy for the manufacture of metal structures in removable and fixed prosthetics.
- Provides extremely stable structures even for large-span bridges with high resistance and tensile strength.
- Biocompatible and extremely corrosion-resistant alloy, free of nickel, cadmium and beryllium.
- CE certified.

## Wide range of indications:

- Crowns and bridges
- Partial denture framework
- Implant-supported prosthetics
- Orthodontic applications

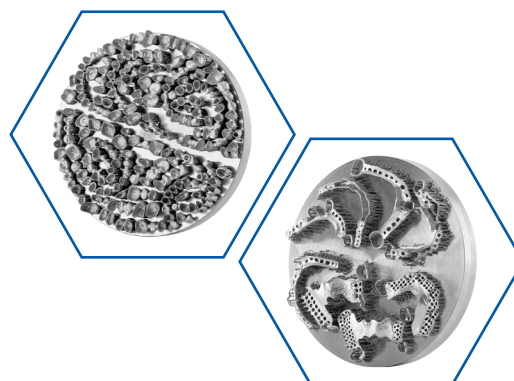

## REF

1750 LaAlloy, á 5 kg

Composition		Properties	
Co	64%	Type	5
Cr	25%	Density g/m <sup>3</sup>	8,6
W	5%	Creep stress Rp 0,2 (Mpa)	879
Mo	4,5%	Tensile strength (Mpa)	1262
Si	1%	E module	251
Mn, C, Fe	< 1%	Elongation A5 %	5,1
		Solidus, liquidus temperatures (°C)	1360 - 1415
		Thermal expansion coefficient 25°C - 500°C (K <sup>-1</sup> )	14,4 x 10 <sup>-6</sup>
		Vickers hardness HV10	435
		Particle size	15-45 µm

# CC DISK NF CoCr

CoCr based disc for CAD/CAM system, free of nickel beryllium, cadmium and lead which fulfils the requirement of the standard EN ISO 22674 for nonprecious alloys and EN ISO 9693 for alloys intended for porcelain fused to metal restorations. It is made of biocompatible alloy, which is easy to polish, has small amount of oxides and is therefore extremely suitable for porcelain. Ideal coefficient of thermal expansion allows usage of wide range of different ceramics.

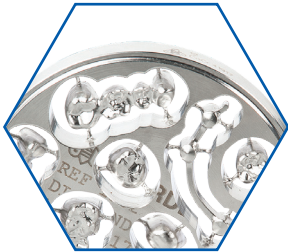

CE 0197  
MD

Composition (Mass-%)	Properties			ORDER NR.	Thickness	
Co	63,0	Type		4	1900	8 mm
Cr	24,0	Vicker's hardness	HV 10	285	1901	10 mm
W	8,0	Coefficient of thermal expansion	25 - 500 °C	$13,9 \times 10^{-6} \text{ K}^{-1}$	1902	12 mm
			20 - 600 °C	$14,0 \times 10^{-6} \text{ K}^{-1}$	1903	13,5 mm
Mo	3,0	0,2 % Elongation limit	Rp 0,2	490 MPa	1904	15 mm
Si	1,0	E-modul	E	ca. 210.000 MPa	1905	18 mm
Nb	< 1	Ductile yield	A5	10 %	1906	22 mm
					1924	24,5 mm
					1907	25 mm

# CC DISK EASY CoCr

CoCr based disc for CAD/CAM system, free of nickel, beryllium, cadmium and lead which fulfils the requirement of the standard EN ISO 22674 for nonprecious alloys and EN ISO 9693 for alloys intended for porcelain fused to metal restorations. It is made of biocompatible alloy.



CE 0197  
MD

Composition (Mass-%)	Properties			ORDER NR.	Thickness	
Co	62,5	Type		4		
Cr	27,2	Vicker's hardness	HV 10	249	1931	10 mm
W	8,2	Coefficient of thermal expansion	25 - 500 °C	$14,4 \times 10^{-6} \text{ K}^{-1}$	1932	12 mm
			20 - 600 °C	$14,6 \times 10^{-6} \text{ K}^{-1}$	1933	13,5 mm
Mn	< 1	0,2 % Elongation limit	Rp 0,2	380 MPa	1928	15 mm
		Temperature solidus, liquidus		1380 °C, 1450 °C	1929	18 mm
		Tensile strength	Rm	553 MPa	1948	22 mm
		E-modul	GPa	167 GPa	1949	25 mm
		Ductile yield	A5	16,9 %		

# CC DISK Ti5

CC DISK Ti5 is made of titanium grade 5. It is used in CAD/CAM milling machines for production of rigid and tough appliances like single crowns, large bridges and implant-based suprastructures. CC DISK Ti5 meets the demand of the standard EN ISO 22674 and EN ISO 9693.



Composition (Mass-%)	Properties	ORDER NR.	Thickness			
Ti	89,8	Type (according to EN ISO 22674)	4	1913	8 mm	
Al	6	Vicker's hardness	HV 10	353	1908	10 mm
V	4	Coefficient of thermal expansion	25 - 500 °C	$9,8 \times 10^{-6} \text{ K}^{-1}$	1909	12 mm
Fe, O	< 1	Density		4,43 g/cm <sup>3</sup>	1910	13,5 mm
		0,2 % Elongation limit	Rp 0,2	780 MPa (N/mm <sup>2</sup> )	1911	15 mm
		Tensile strenght		860 MPa (N/mm <sup>2</sup> )	1912	18 mm
		Ductile yield	A5	10 %	1921	20 mm
					1922	22 mm
					1923	25 mm

## A NEW GENERATION OF TOP AESTHETICS

Multilayer zirconia discs are distinguished by their brilliant aesthetics, thanks to their incredible light transmission and flawless color gradient.

All together, they provide extremely natural, beautiful and lively restorations.

## INDICATIONS

	Veneer	Inlay & onlay	Reduced crown	Full contour crown	Copyng	Full contour anterior bridge 3(unit)	Full contour posterior bridge 3(unit)	Full contour bridge (≤7unit)	Full contour bridge (≤14unit)	Abutment
CC DISK Zr		●		●	●	●	●	●	●	●
CC DISK Zr HT		●	●	●	●	●	●	●	●	
CC DISK Zr HT Multilayer		●	●	●	●	●	●	●		
CC DISK Zr SMILE Multilayer	●	●	●	●	●	●				

\*For detailed information, see the attached instructions for use.

# CC DISK Zr HT Multilayer

The CC DISK Zr HT Multilayer is made of biocompatible pre-sintered ZrO<sub>2</sub>. It has excellent mechanical properties, chemical stability, biocompatibility and translucency. It is intended for use in CAD/CAM milling machines for the production of full anatomical restorations, as for classical frames, meant for porcelain veneering that does not exceed 3 units. Due to its exceptional light transmission of 46 % at 1 mm and translucency, it is specifically designed for aesthetic solutions in the anterior as well as the posterior area. It meets the demands of the standard for dental ceramic EN ISO 6872 type II, class 5.

ORDER NR.	Thickness	Color
1952MLHT + color	14 mm	A1, A2, A3, A3.5, A4, B1, B2, B3, C1, C2, C3, D2, D3, BL1, BL2, BL3
1954MLHT + color	18 mm	A1, A2, A3, A3.5, A4, B1, B2, B3, C1, C2, C3, D2, D3, BL1, BL2, BL3
1956MLHT + color	22 mm	A1, A2, A3, A3.5, B1, B2, B3, C1, C2, D2, D3, BL1, BL2, BL3

Composition	(Mass-%)	Properties
ZrO <sub>2</sub> + HfO <sub>2</sub> + Y <sub>2</sub> O <sub>3</sub>	≥ 99	Translucency 46 %
Y <sub>2</sub> O <sub>3</sub>	< 8	Flexural strength 900 - 1100 Mpa
Al <sub>2</sub> O <sub>3</sub>	≤ 0,1	Thermal expansion 25 - 500 °C 10,5 x 10 <sup>-6</sup> K <sup>-1</sup>
Other	< 0,5	Sintered density g/cm <sup>3</sup> > 6,02
		Radioactivity Bq/g < 0,10
		Solubility µg/cm <sup>2</sup> < 50



# CC DISK Zr SMILE Multilayer

The CC DISK Zr SMILE Multilayer is made of biocompatible pre-sintered ZrO<sub>2</sub>. It has excellent mechanical properties, chemical stability, biocompatibility and translucency. It is intended for use in CAD/CAM milling machines for the production of full anatomical and cut-back restorations, as for classical frames, meant for porcelain veneering that does not exceed 3 units. Due to its exceptional light transmission of 49 % at 1 mm and translucency, which is close to a lithium disilicate, it is specifically designed for aesthetic solutions in the anterior area. It meets the demands of the standard for dental ceramic EN ISO 6872 type II, class 4.

ORDER NR.	Thickness	Color
1952SML + color	14 mm	A1, A2, A3, A3.5, B1, B2, B3, C1, C2, D2, D3
1954SML + color	18 mm	A1, A2, A3, A3.5, B1, B2, B3, C1, C2, D2, D3
1956SML + color	22 mm	A1, A2, A3, A3.5, B1, B2, B3, C1, C2, D2, D3

Composition	(Mass-%)	Properties
ZrO <sub>2</sub> + HfO <sub>2</sub> + Y <sub>2</sub> O <sub>3</sub>	≥ 99	Translucency 49 %
Y <sub>2</sub> O <sub>3</sub>	< 10	Flexural strength 600 - 900 Mpa
Al <sub>2</sub> O <sub>3</sub>	≤ 0,1	Thermal expansion 25 - 500 °C 10,5 x 10 <sup>-6</sup> K <sup>-1</sup>
Other	< 0,5	Sintered density g/cm <sup>3</sup> > 6,02
		Radioactivity Bq/g < 0,10
		Solubility µg/cm <sup>2</sup> < 50

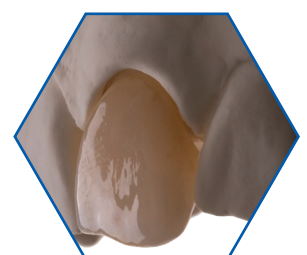

# CC DISK Zr / CC DISK Zr HT

CC DISK Zr disc is made of biocompatible pre-sintered ZrO<sub>2</sub>. It has excellent mechanical properties, chemical stability, biocompatibility and translucency. It is intended for use in CAD/CAM milling machines for production of full anatomical restorations, as for classical frames meant for porcelain veneering. CC DISK Zr meets the demands of the standard for dental ceramic EN ISO 6872, type II, class 5.

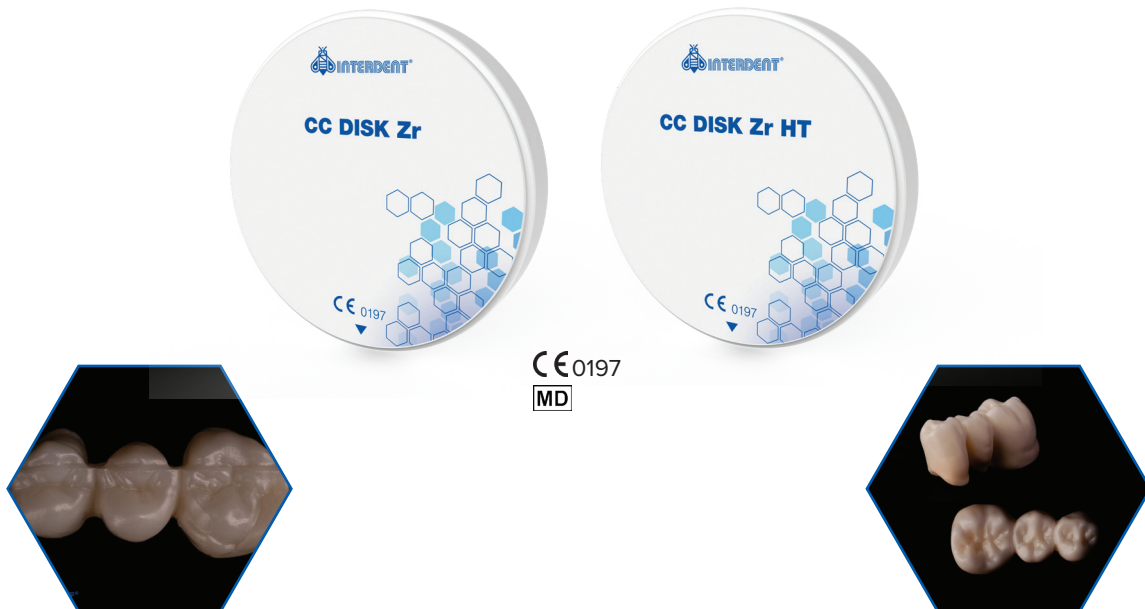

Composition (Mass-%)	CC DISK Zr	CC DISK Zr HT	CC DISK Zr HT preshade
ZrO <sub>2</sub> + HfO <sub>2</sub> + Y <sub>2</sub> O <sub>3</sub>	≥ 99	≥ 99	≥ 99
Y <sub>2</sub> O <sub>3</sub>	4,5 - 10,0	4,5 - 10,0	4,5 - 10,0
HfO <sub>2</sub>	≤ 5	≤ 5	≤ 5
Al <sub>2</sub> O <sub>3</sub>	≤ 0,5	≤ 0,5	≤ 0,5
Other	≤ 0,5	≤ 0,5	≤ 0,5
<b>Properties</b>			
Translucency	42 %	43 %	43 %
Flexural strength	1400 ± 100 MPa	1250 ± 100 MPa	1250 ± 100 MPa
Coefficient of thermal expansion	10,5 × 10 <sup>-6</sup> K <sup>-1</sup>	10,5 × 10 <sup>-6</sup> K <sup>-1</sup>	10,5 × 10 <sup>-6</sup> K <sup>-1</sup>
Sintered density g/cm <sup>3</sup>	> 6,02	> 6,02	> 6,02
Radioactivity Bq/g	< 0,10	< 0,10	< 0,10
Solubility µg/cm <sup>2</sup>	< 50	< 50	< 50

CC DISK Zr		
ORDER NR.	Thickness	Color
1950	10 mm	colourless
1951	12 mm	colourless
1952	14 mm	colourless
1953	16 mm	colourless
1954	18 mm	colourless
1955	20 mm	colourless
1956	22 mm	colourless

CC DISK Zr HT		
ORDER NR.	Thickness	Color
1951HT + color	12 mm	colourless, A1, A2, A3
1952HT + color	14 mm	colourless, A1, A2, A3, A3.5, A4, B2, B3, B4, C3, C4, D2, D4
1953HT + color	16 mm	colourless, A1, A2, A3
1954HT + color	18 mm	colourless, A1, A2, A3, A3.5, A4, B2, B3, B4, C3, C4, D2, D4
1955HT + color	20 mm	colourless, A1, A2, A3, B2, D2
1956HT + color	22 mm	colourless
1957HT + color	25 mm	colourless, A1, A2, A3, B2, D2

# CC DISK PEEK

Extremely light, biocompatible and high performance polymer PEEK (polyether ether ketone) material is an alternative to classic metal denture bases and many other indications. Strong and resistant material due to small weight and its ability to absorb loads, represents a completely new comfort for patients. It meets the demands of EN ISO 20795-1 and EN ISO 10477.



ORDER NR.	Thickness	Color
1410	12 mm	Ivory
1411	14 mm	Ivory
1412	16 mm	Ivory
1413	18 mm	Ivory
1414	20 mm	Ivory
1415	25 mm	Ivory
1420	12 mm	White
1421	14 mm	White
1422	16 mm	White
1423	18 mm	White
1424	20 mm	White
1425	25 mm	White
1431	14 mm	Pink
1432	16 mm	Pink
1433	18 mm	Pink
1434	20 mm	Pink
1435	25 mm	Pink



## Properties

Density	1,52 g/mL
Water sorption (23 °C)	6,1 µg/mm <sup>3</sup> (0,4 %)
Stress at yield	110 Mpa
Tensile modulus	5100 MPa
Tensile elongation at break	5 %
Flexural strength	178 Mpa
Flexural modulus	4800 Mpa
Charpy notched impact strength	5,1 kJ/m <sup>2</sup>
Cytotoxicity test	No cytotoxic effect

# CC DISK WAX

CC DISK WAX is made from temperature stable micro wax which burns out without residues. The stability of the wax composition allows the milling machine to mill the narrowest space with high efficiency and gives smooth and homogeneous surface. The dropping point of 120 °C excludes the danger of chipset melting, therefore it can be easily cleaned from the milling unit.



ORDER NR.	Thickness	Type
1980	20 mm	hard - beige colour
1981	20 mm	normal - grey colour
1982	14 mm	normal - grey colour



# CC DISK PMMA

CC DISK PMMA is used in CAD/CAM milling machines for production of temporary restorations, gingiva formers directly after implantation, for study try-ins and for checking the occlusal contacts before the final restoration (out of Zr or CoCr) is produced.



ORDER NR.	Thickness	
1931 + color	12 mm	
1932 + color	14 mm	
1933 + color	15 mm	
1934 + color	16 mm	A1, A2, A3, A3,5
1935 + color	18 mm	B1, B2, B3, C1, C2,
1936 + color	20 mm	D2, E1, E2,
1937 + color	25 mm	BL1, BL2, BL3
1945 + color	30 mm	
1946 + color	35 mm	
1939 + color	18 mm	A3 - 3 - layer

## Properties

Vicker's hardness	26,6 MPa (N/mm <sup>2</sup> )
E-modul	2771 MPa (N/mm <sup>2</sup> )
Flexural strength	114 MPa (N/mm <sup>2</sup> )

# CC DISK PMMA Multilayer

The CC DISK PMMA Multilayer is intended for use in CAD/CAM milling machines for the production of temporary restorations, gingiva formers directly after implantation, for study try-ins and for checking the occlusal contacts before the final restoration is produced. It is a multi-layered disc, composed of five shades of colour with gentle colour transitions that give a natural appearance.



ORDER NR.	Thickness	
1941ML + color	15 mm	A1, A2, A3, A3,5,
1944ML - color	16 mm	B1, B2, B3, B4, C1,
1942ML + color	18 mm	C2, C3, C4, D2,
1943ML + color	20 mm	D3, D4,
		BL2, BL3

## Properties

Vicker's hardness	26 MPa (N/mm <sup>2</sup> )
E-modul	2771 MPa (N/mm <sup>2</sup> )
Flexural strength	114 MPa (N/mm <sup>2</sup> )

# CC DISK PMMA Pink

CC DISK PMMA Pink is used in CAD/CAM milling machines for production of base for total and partial prosthesis and for immediate load denture on the dental implants as a long term provisional solution.

## ORDER NR. Thickness

1960	25 mm
1961	27 mm
1962	30 mm

## Properties

Vicker's hardness	26,6
E-modul	2771 MPa (N/mm <sup>2</sup> )
Flexural strength	114 MPa (N/mm <sup>2</sup> )
Residual monomer	< 1%



CE 0197  
MD

# CC DISK PMMA Transparent

CC DISK PMMA Transparent is used in CAD/CAM milling machines for production of reduced frameworks for casting, full or partial constructions for press ceramic and for try-ins before the production of final restorations. Burns out without residues.

## ORDER NR. Thickness

1963	12 mm
1964	14mm
1965	15 mm
1966	16 mm
1967	18 mm
1968	20 mm
1969	25 mm

## Properties

Made of 100 % organic material. Burns out without residue.



CE  
MD

# CC DISK PMMA X-Ray Opaque

CC DISK PMMA X-Ray Opaque is used in CAD/CAM milling machines for making x-ray visible teeth on implant diagnostic template to see the placement of the teeth while planning the position of the dental implant.

## ORDER NR. Thickness

1970	12 mm
1971	14mm
1972	15 mm
1973	16 mm
1974	18 mm
1975	20 mm
1976	25 mm

## Properties

Contains x-ray visible powder.

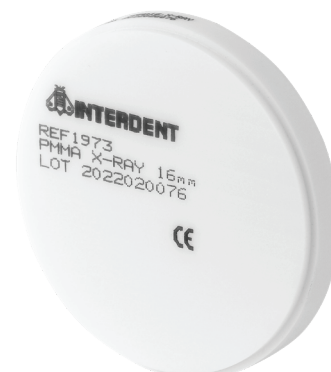

CE  
MD

# SUPPORT AND EDUCATION

Whether you are deciding to buy a milling unit, you just made a purchase or you have been using the milling unit for a longer period of time Interdent CAD/CAM Team is here for you!

## I am deciding to buy

In the company INTERDENT we will be happy to assist you with your very important decision. We will recommend the most suitable unit for your needs that will optimize your working processes in the laboratory or clinic.



## I just made a purchase

The first major step has already been realised and thus enter the INTERDENT CAD/CAM Team, where you will find professional approach of experienced dental technicians and CAD/CAM specialists. You will learn how to use the machine and materials. Together with them you will connect your dental expertise with hightech computer technology and learn the foundations for optimal results and efficient work.



## I am already using a milling unit for a longer period of time!

CC LITE, CC TRENDY, CC newTRENDY+, CC newCOSMO, CC newCHIC, CC COOL, CC UNIVERSE, CC Force, CC Force+, CC Foce Pro, CC ForceForce+ Pro or CC TRIM milling unit has become the centre of your practice. After a certain time, new questions occur, so the only effective, available, fast and professional support is the most important thing you need and that is what INTERDENT CAD/CAM team will provide you. We will be at your disposal either in person or over the phone or camera.



# MILLING CENTER

With our range of services, we enable your dental laboratory to take full advantage of all the currently available digital working processes in the dental industry without additional investment, thus reducing your costs and, most importantly, improving the quality and productivity of your work.

## Accuracy

We guarantee high precision technology, both for design and for the implementation. Only certified material with LOT number for traceability is used.

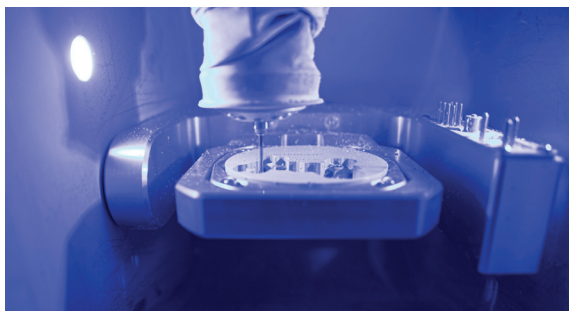

## Flexibility

There are different materials and thicknesses available for different indications. Material: CoCr, Ti5, Zr, Zr HT, Zr-coloured, Zr HT Multilayer, Zr HT Smile Multilayer PMMA, PMMA Pink, PMMA Transparent, PEEK, PMMA X-ray, glass-ceramic, lithium disilicate,...



## Delivery

STL format or model, which arrives till 12 am is processed within 48h. It does not apply to Saturdays, Sundays and public holidays. Delivery time is stated in the price list and depends on the general conditions of the deliverer.



## Simplicity

Simple high-tech technological process. You can send to our milling centre either document in STL format or a model which must be adequately prepared.



## Open system

Our service is open. It can accept files from a variety of different systems that are available in STL format.



## Order

For the design in STL format the order can be done through the website <https://cadcam-interdent.si/Oddaj-narocilo/> or email address [cadcam@interdent.cc](mailto:cadcam@interdent.cc). To order a scan and design, the model needs to be sent by post to Interdent d.o.o, Milling center, Opekarniška cesta 26, 3000 Celje, Slovenia.

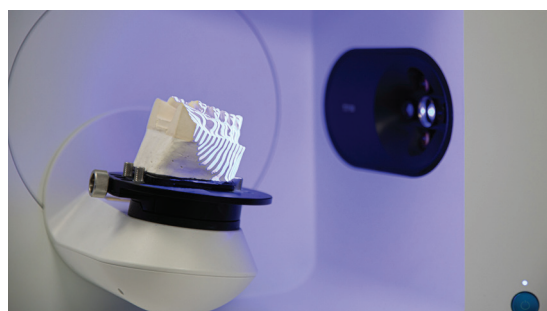

# MILLING CENTER

## CNC Technology Milling

Extremely precise CNC technology has been offering users ultraprecise products based on digital scanning and digital design for a couple of decades. The technology in dentistry itself goes back a long way, to the 80s of the last century, which means that throughout all this time, the process has been optimized almost to perfection. Today, this evolution is reflected in high-quality and extremely precise, milled structures without internal stresses and deformations.

Milling is performed on modern Interdent milling units which, with their sophisticated milling process strategies, ensure unparalleled precision and enviable surface treatment.

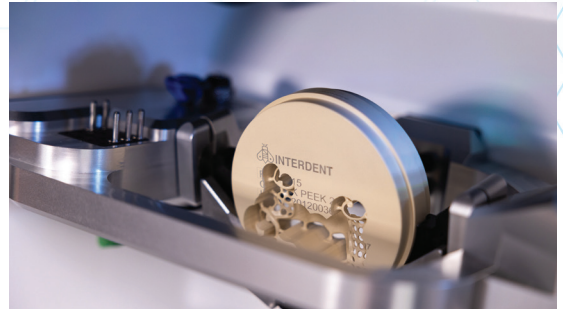

## Metal 3D printing

Metal printing covers a wide range of combined technologies to achieve superior results. DMLS® (Direct Metal Laser Solidification) is a proven PBF (Power bed fusion) technology for almost three decades, which is today the standard in 3D printing of metal parts. The DMLS method was primarily used for production in demanding industries such as aerospace, automotive, medical, toolmaking ... These industries require the same quality of parts as would be achieved with conventional casting processes.

DMLS laser printing offers a new, unmatched quality in the production of metal frames. The micro-structured surface of the frames with a print resolution of up to 30 µm, ensures extremely precise constructions, without internal stresses. The extremely powerful laser provides an incomparable density of material, with excellent tensile strength. In addition, thanks to dust control technology, the quality of the components is automatically monitored and is constant.

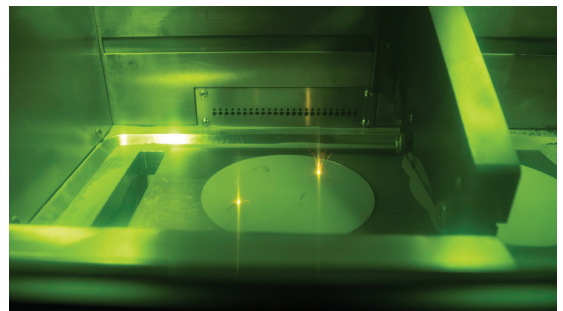

The quality and stability of the beam and the 200-watt power of the laser fiber ensure optimal and consistent conditions for the production of high-quality components. A small laser dot with excellent resolution is ideal for making very complex and delicate parts. Printer is ideal for printing dental crowns, bridges and partial denture frameworks as well as other medical devices.





INTERDENT d.o.o.  
Opekarniška cesta 26 · SI - 3000 CELJE · SLOVENIA  
T: +386 (0)3 425-62-00 · F: +386 (0)3 425-62-10  
E: [info@interdent.cc](mailto:info@interdent.cc) · [www.interdent.cc](http://www.interdent.cc)  
Facebook: Interdent Slovenia  
Version: 17.06.2026 (EN)